

 Σ **_F8S**
 SIGMA

 Σ **_G5S II**
 SIGMA

 Σ **series**
 SIGMA

SMT Innovation
Premium Modular Moulder

F8S: Fastest speed in its class! Produce 150,000 CPH with 4 beams and 4 heads

G5S II: With 2 beams and 2 heads ensure high speed and versatility, support wide component range

Direct drive high-speed head
 Multi-functional head
 Overdrive motion

Maximum feeder count
 120 kinds (8 mm tape)

Handling large PCBs
 L 610 x W 510 mm
 L 1,200 x W 510 mm (optional)

Component range
 0201 mm chip to 72 mm² & 150 x 26 mm
 35 mm height, up to 100 N

Overdrive motion delivers streamlined high-efficiency production

Overdrive motion (Σ -G5S II)

- Simultaneous mounting by both heads allows for higher-efficiency production!
- Overdrive allows component pickup by either head from both the front and rear feeder carts without any restrictions.
- Maximum Flexibility! Overdrive allows the sharing of tray & tape feeders, nozzle stations and options such as coplanarity checkers, with no restrictions on component placement while lowering your initial investment costs.

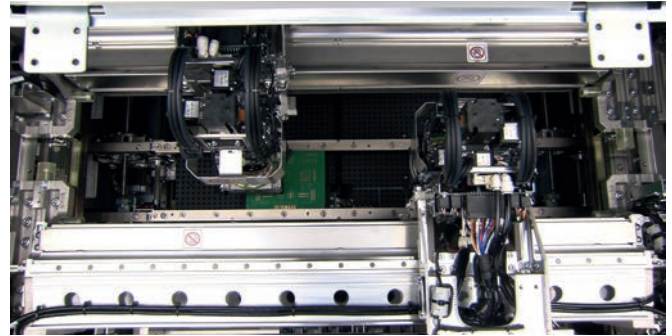

▲ Σ -G5S II: simultaneous mounting via overdrive motion

DD head offers high speed & accuracy with less maintenance

High-speed one-by-one pickup & mounting

- Rotary direct drive head (DDH) has a simple design using no external drive parts such as gears or belts yet gives high-accuracy mounting.
- Using 15 nozzles per head, our DDH produces 45,000 CPH with class leading component range!



Side-view function

- Detect pickup status (components/no components / vertical), measures components, and automatically adjusts the mounting height with no impact on performance.
- Also supports mounted component 'bring-back checks' (a nozzle check post placement).



Widest high-speed head component range in the industry!

Head variations & compatible components

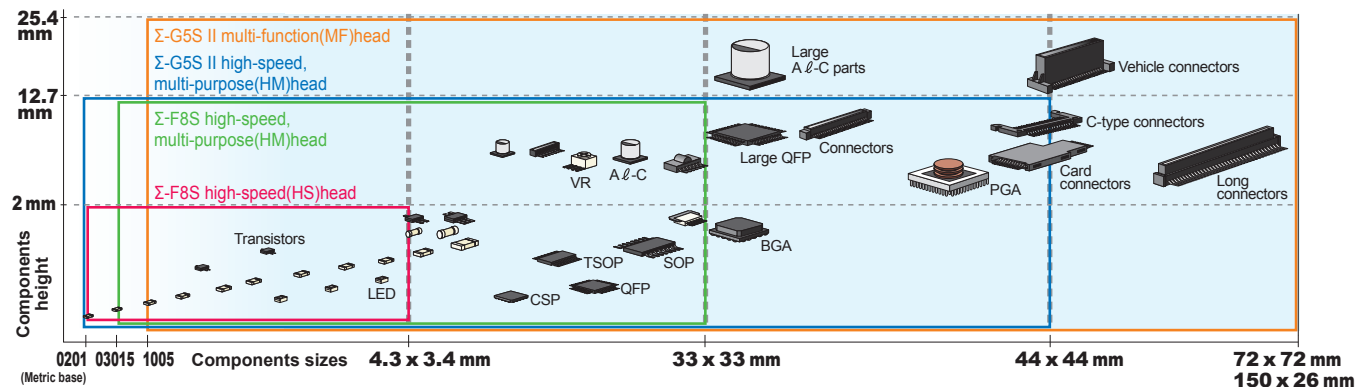

Includes coplanarity for high-speed and high-reliability

- Uses the YS series highly rated camera unit.
- Scan time reduced 50% by using 3D camera system.



Reduced PCB transfer loss by enlarging buffer size (Σ G5S II)

Using PCB standby for part of mounting area, allowed increasing buffer from conventional size of L 280 mm to L 410 mm.

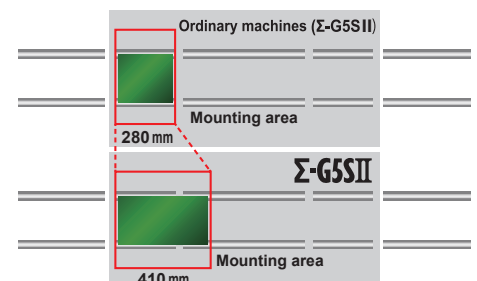

'SL' Feeder 'Self-Loading/Splice-Less' innovates components supply tasks!

SL Feeder

- Auto-loading feeders lower the burden on the operator so that anyone, anytime, can easily set components for feed and supply.
- Supports continuous, non-stop operation and needs no splicing!
- Not peeling the cover tape prevents static charges, dust and having to collect the cover tape.

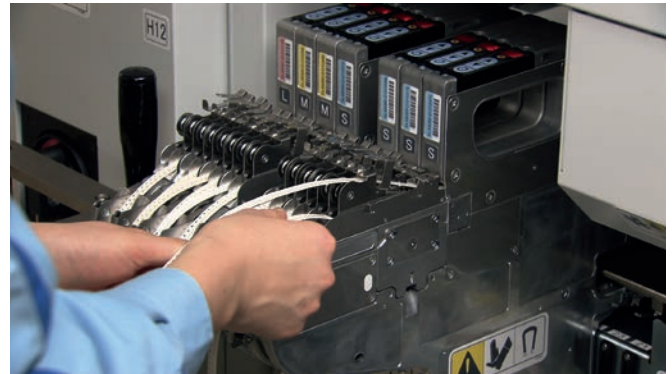

Wide-ranging & full-feature application software

LISA

(Line Information Support & Administration)

- Centralized line data control
- Line operation management
- Allows for pattern program modification without line interruption
- Bad mark information, PCB segment recognition mark information

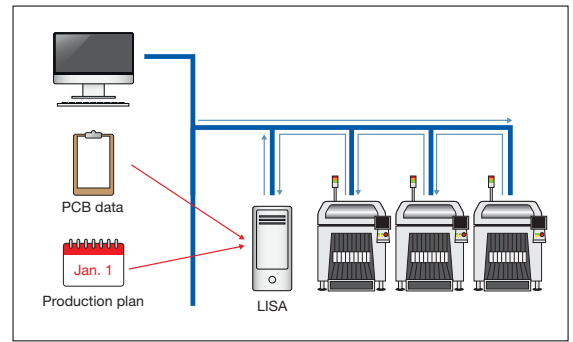

▲ LISA system

ACV

(Advanced Component Validation)

- Feeder setup error checking
- Component shortage alarm
- Traceability support

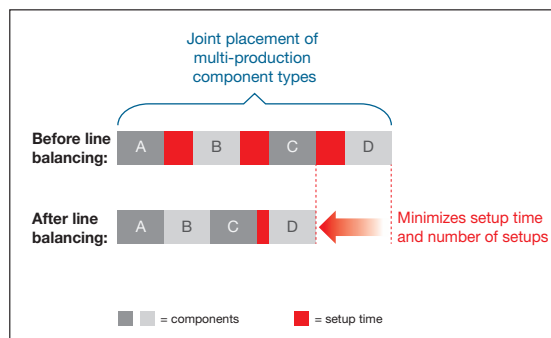

▲ Family setup



▲ Setup verification

Multi-product line balance

- Family setup function
- Setup scheduler function

Full range of feeder and supply device options to match your production format

- Feeder carriage exchange
- Multi-stage tray feeder (Σ -G5S II)
- Stacking stick feeder (Σ -G5S II)
- Coplanarity checker (Σ -G5S II)
- Flux coater unit
- ACV (Advanced Component Validation)
- LISA (Line Information Support & Administration)
- Application software



▲ Stacking stick feeder

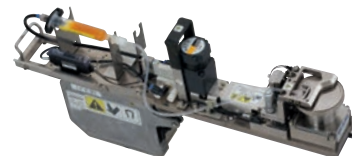

▲ Flux coater unit



▲ Feeder carriage exchange



▲ Multi-stage tray feeder

Specifications	Σ -F8S SIGMA	Σ -G5S II SIGMA
Head configuration	4 heads/module	2 heads/module
Mounting tact time (max.)*	Single lane: 136,000/87,400 CPH IPC9850	High-speed head: 90,000/56,500 CPH IPC9850
	Dual lane: 150,000/109,800 CPH IPC9850	Multi-functional head: 10,800 CPH/head
Applicable components	High-speed head: 0201 mm chip to 4.3 x 3.4 mm (H: 2.0 mm)	High-speed head: 0201 mm chip to 44 mm ² , H: 12.7 mm
	High-speed multi-purpose head: 03015 mm chip to 33 x 33 mm (H: 12.7 mm)	Multi-functional head: 1005 mm chip to 72 mm ² , H: 25.4 mm, connectors 150 x 26 mm
Mounting accuracy**	High-speed head: 0201 mm chip: $\pm 25 \mu\text{m}$ (3 σ)	High-speed head: 0201 mm: $\pm 25 \mu\text{m}$ (3 σ)
	High-speed multi-purpose head: 03015 mm chip: $\pm 25 \mu\text{m}$ (3 σ)	Multi-functional head: IC: $\pm 15 \mu\text{m}$ (3 σ)
Applicable PCB size	Single or dual lane: L 50 x W 50 mm to L 330 x W 250 mm	Single lane: L 50 x W 50 mm to L 610 x W 510 mm (OP: L 1,200 x W 510 mm)
	Optional: L 50 x W 50 mm to L 381 x W 510 mm	Dual lane: L 50 x W 84 mm to L 610 x W 250 mm
Number of component types	Max. 80 types (conversion for 8 mm tape feeder)	Max. 120 types (conversion for 8 mm tape feeder)
External dimensions	L 1,280 x D 2,240 x H 1,450 mm	L 1,280 x D 2,240 x H 1,450 mm
Weight	Approx. 1,940 kg (excluding cart)	Approx. 1,800 kg (excluding cart)
Power supply	3-phase AC 200 V ± 10 V, 50/60 Hz	3-phase AC 200 V ± 20 V, 50/60 Hz
Supplied air pressure	Air supply source: 0.45 to 0.69 MPa (4.6 to 7 kgf/cm ²)	Air supply source: 0.45 to 0.69 MPa (4.6 to 7 kgf/cm ²)

*Under optimum conditions. **Under standard conditions as defined by Yamaha Motor.

External dimensions (mm)

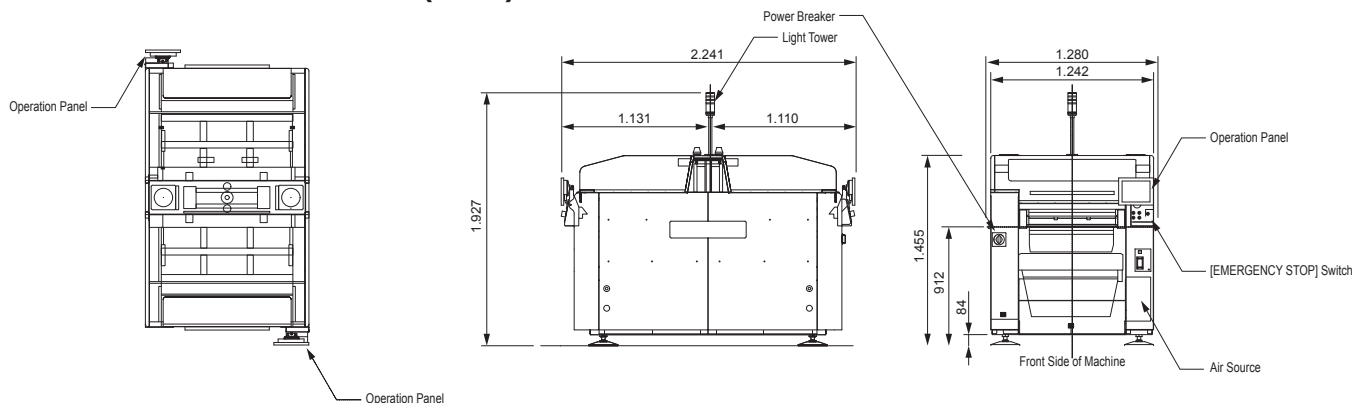

Yamaha Motor Europe N.V.
 Niederlassung Deutschland, Geschäftsbereich IM
 German Branch Office, IM Business
 Hansemannstrasse 12 · 41468 Neuss · Germany
 Tel: +49-2131-2013520
 info-ymeim@yamaha-motor.de
 www.yamaha-motor-im.eu